



ORBIT WINCH™

with QuickTrim™

PRODUCT MANUAL

ELECTRIC MOTOR UNIT, 12V & 24V
TO SUIT SELF-TAILING ORBIT WINCH™ 40QT

SERIAL No.:

Winch Versions:

V40 V1.0 >

FOR USE WITH:

RA6402

RA640201100

RA640201101

RA640201200

RA640201201

RA640251100

RA640251101

RA640251200

RA640251201



CONTENTS

INTRODUCTION	3
SAFETY NOTES	4
FEATURES	5
WINCH PARTS LIST AND EXPLODED VIEW	6
MOTOR PARTS LIST	7
MOTOR EXPLODED VIEW	8
INSTALLATION	9
DRILLING TEMPLATE PUSH BUTTON	15
ELECTRICAL CONNECTION DIAGRAM	17
QUICKTRIM™	18
USING QUICKTRIM™	19
SERVICE & MAINTENANCE	20
ELECTRIC MOTOR SERVICE & MAINTENANCE	21
TROUBLESHOOTING	22
STATUS CODES	23
WINCH INSTALLATION DIMENSIONS	24
DRILLING TEMPLATE	25

40QT ORBIT WINCH™

INTRODUCTION

Your Ronstan Orbit Series winch is ready to provide you with many years of easy sail handling and reliable service.

Ronstan has been designing and manufacturing equipment for sailboats for more than 70 years. We are also known for our range of Andersen Stainless Steel Winches®, recognised around the world for their exceptional finish and enduring quality. The Orbit Series draws on the same engineering and manufacturing expertise to deliver a high-efficiency winch in lightweight aluminium. Controlled grip, smooth performance without excessive rope wear, and a patented QuickTrim™ feature on selected models that makes fine tuning a breeze.

You have some performance options to choose from, which need to be enabled before installing the winch, so please read this manual carefully from start to finish before proceeding.



RA6402 SPECIFICATIONS

Power ratio:	1st speed: 8:1 2nd speed: 40:1
Rope dia.:	7-12mm (9/32"-1/2")
Weight:	3.1 kg (6.8 lb)
MWL:	850 kg (1870 lb)

BATCH NUMBER

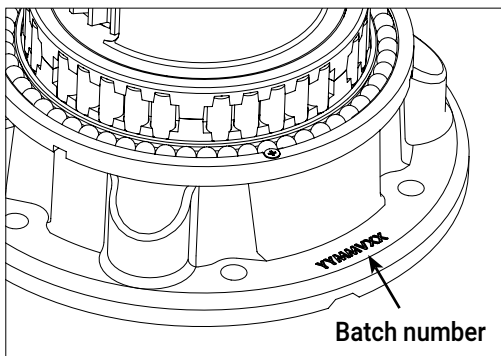

To assist with any future service inquiries, your winch has a batch number that is stamped onto the base of the centre stem in the location shown below. The self-tailing arm and drum need to be removed to access the batch number (refer steps 2 & 3 of the installation instructions).

SAFETY NOTICES

Read All Safety Notices and Product Manuals

Do not install or operate this winch before reading and fully understanding the contents of this Product Manual.

Stay Alert When Operating

Winches are very powerful and have the potential to cause significant damage and/or serious injury if used improperly or without due caution and vigilance.

Operators Must Be Trained

Help prevent significant damage and/or serious injury by ensuring any person operating a winch has a thorough understanding of its proper operation and is aware of the potential hazards involved. As a minimum, all winch operators must read and understand this Safety Notice Sheet and the Product Manual.

Particular attention is drawn to the following points:

- Children and others not qualified to operate a winch must be kept at a safe distance from the winch and any rigging or fittings that are under load.
- Long hair and/or loose clothing must be tied back to avoid being caught in the winch.
- In the event of a rope override or other fault with an electric winch, stop the winch and turn off power before attempting to resolve the problem.

Avoid Accidental Operation

Remove winch handles when not in use, and turn off power to electric winches to help avoid unsupervised or unintentional operation. Failure to do so could result in significant damage and/or serious injury.

Maintenance

Turn off power to an electric winch before performing any maintenance or service tasks. Failure to do so could result in significant damage and/or serious injury.

Lifting Operations

The winch must not be operated with the rope in the self tailer when used in any kind of lifting operation. Any lifting operations should be conducted by two persons in order to maintain constant visual contact with the object being lifted. Furthermore, the self tailer must not be used as a cleat for a rope used to lift or suspend any object. The rope must be secured properly by tying off or leading to a suitable fitting such as a cleat or bollard.

Failure to observe these precautions could result in serious injury or death.

DO NOT DISCARD

FEATURES

- Highest quality winch featuring a machined aluminium drum for light weight and ultimate durability, vertical Power Ribs™ for maximum grip and minimum rope wear, and superior engineering for reliability, long service life and low maintenance.
- Easy to install and service. The motor unit has internal controller and contactor so electrical connection is simple. The winch can be serviced independently of the motor unit, without removing it from the deck.
- Illuminated "intelligent" push button with integrated LED indicates system power is on and, in conjunction with the controller, will flash status codes that assist with troubleshooting.
- High quality European engineered and manufactured motor, with matched gearbox for optimal speed and load capacity.
- Unrivalled levels of monitoring and protection including Integrated Overload Protection, Thermal Overload Protection, Accidental Start Protection, Low Voltage Detection, Continuous Run Time Limiting.
- The motor unit can be rotated relative to the winch during installation to suit restricted under-deck space (10 positions at 36° increments.)
- 2 speed manual winch operation is always possible by simply inserting a standard winch handle.
- QuickTrim™ operation works with or without winch handle being inserted.
- Clutch-less design enables the handle to safely remain inserted while the winch is operated electrically.

INCLUDED

Included in your E1 Electric Motor Unit:

- Motor unit
- Deck plate [37]
- Drive gear [33]
- Push button incl. 500 mm (19 5/8") control cable [A1]
- Push button gasket [A2]
- Eye-bolt [A4]
- Drilling template [A3]

Numbers in [] above and in instructions refer to the item number in the electric motor parts list, see pages 7 & 8.

REQUIRED

Tools & fasteners required for installation:

- Phillips head screwdrivers - #2
- Drill bit, Ø6.5mm for M6 mounting bolts (or 9/32" holes for 1/4" bolts)
- Ø54 mm (2 1/8") hole-saw, or jigsaw
- 4mm hex key (manual conversion only)
- 5mm hex key
- 5x M6 or 1/4" Grade 316 stainless steel fasteners (length as required for deck thickness). Use of A4-70 DIN7991 hexagon socket cylinder head screws is recommended, installed at a torque setting of no more than 7.1Nm as per industry standards
- 5x M6 or 1/4" ID large diameter Grade 316 stainless steel washers or backing plate (to match drilling template)
- 5x M6 or 1/4" nuts Grade 316 stainless steel to suit above mounting fasteners
- Spanner, to suit mounting fasteners
- Solvent (white spirits/mineral spirits) - to clean deck prior to applying sealant
- Sealant/ bedding compound
- Tef-Gel™ isolating paste (Tef-Gel™ is a trademark of Ultra Safety Systems, Inc.)
- Medium strength thread lock.
- Ø3 mm (1/8") drill
- Ø25 mm (1") drill or hole saw
- Wire crimping tool/pliers
- Marine grade electrical power wire with Ø8mm terminals (see table page 16)
- Circuit breaker/fuse; available separately (see table page 16)
- Cable fastening clips

PARTS LIST AND EXPLODED VIEW

Item No.	Qty	Description	Part No.
1	1	Self-tailing arm assembly	996017
2	1	Closing plate	990876
3	1	Closing washer	990978
4	3	Bolts, self tailer attachment	990981
5	1	Rope splitter	990896
6	1	Self tailer & QuickTrim™ assembly	996016
6.1	3	Locking pin	996015
7	1	Drum	990866M
8	3	Nut, M3	NU3
9	1	Roller bearing assembly	990874
10	1	Ball bearing race assembly	996012
11	1	Shaft assembly	990998
11.1	4	Pawl springs	713300
11.2	4	Pawls	713200
12	1	Spacer*	990871
13	1	Drive gear	711701
14	1	Ratchet gear	990870
15	1	Gear axle	990878*
16	1	Output gear	996037*
17	1	Centre stem assembly	990883
17.1	2	Shaft bearing	996034
17.2	2	Top hat bearing inserts	536300*
17.3	1	Base plate	996039*
17.4	2	Hex socket cyl. head screw, M5x16	SC5-516*
18	1	Screw SS, M3 x 10 Cross CSK Head	SC3-310

*These parts from the manual 40QT winch are not used when installed as an E1 electric winch

Winch Pawl & Spring Kit RA710052 contains 8 pawls and 16 springs.

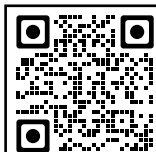

Refer to the diagrams and the exploded view for part and assembly details.

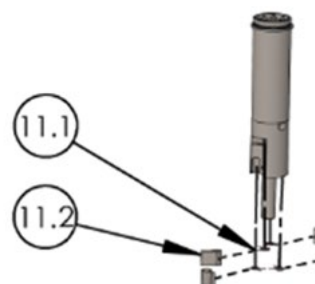
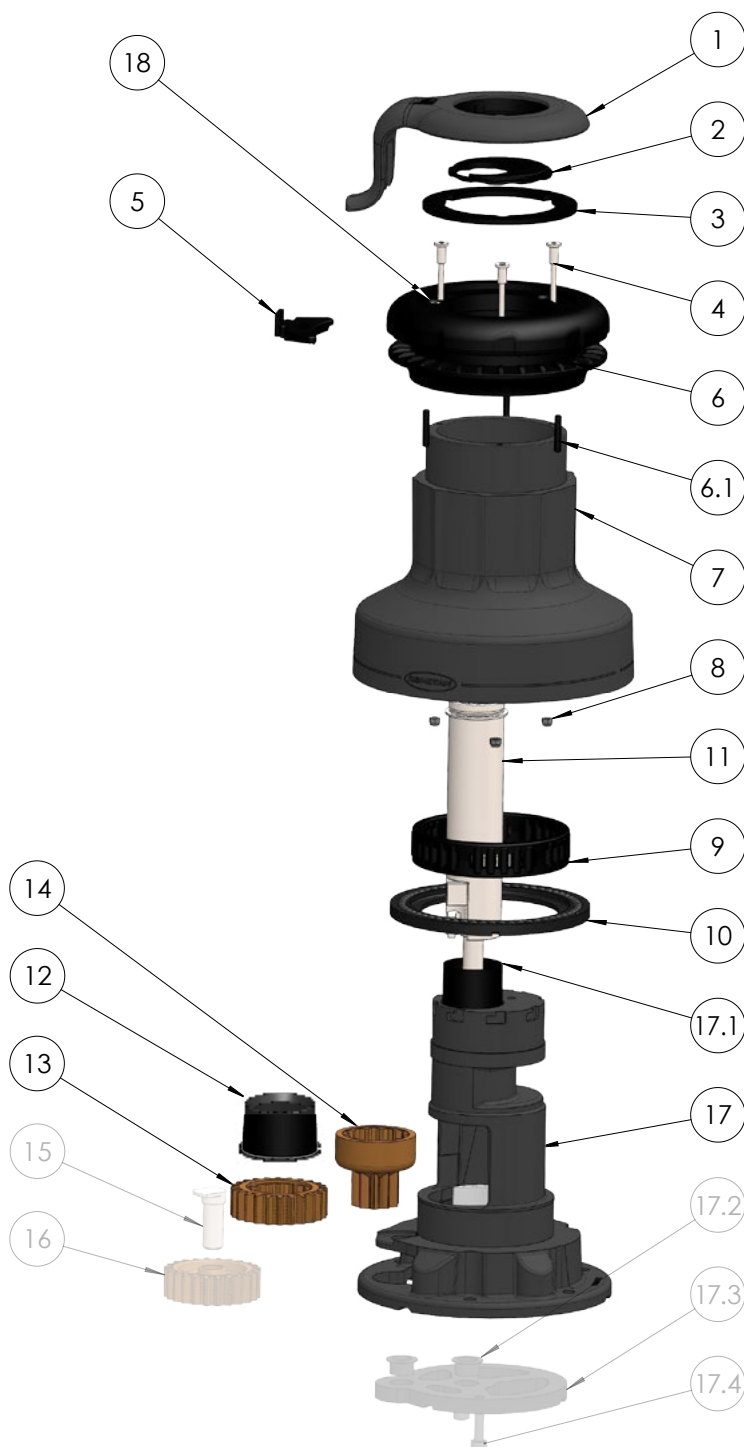

MOTOR PARTS LIST

(exploded view next page)

40QT SINGLE SPEED 12V & 24V

Item No.	Qty	Description	Part No.
30	1	Motor E1 1000W 12V, incl. Controller	777450
30	1	Motor E1 1000W 24V, incl. Controller	777460
31	1	Standard gear box unit for 30/40QT	990993
32	1	Gear bearing 30/40QT	990992
33	1	Drive gear	990982
34	1	Compression ring	RD100430
35	1	Centre locknut	990986
36	1	Isolation washer	990999
37	1	Deck plate 40QT E1	990965
38	1	Top hat bearing insert	536300
39	1	Seal dust cover	990994
40	1	Sealing ring	RD100022
41	1	Plain bearing	990989
42	4	Screw	DIN933-A4-M6X60
43	1	Gear clamp ring	990991
44	1	O-Ring	RD100434
45	1	Driveshaft housing 30/40QTE	990984
46	1	Washer	536302
47	1	Drive shaft	990985
48	2	Pawl	713300
49	2	Spring	713200
50	1	Washer	835000
51	1	Bush	RD100439
52	1	Key for ratchet gear wheel	DIN6885-A-8X7X20
53	1	Ratchet gear wheel	776112
54	2	Screw	DIN933-A4-M6X20
55	4	Washer	DIN125-A4-Ø6,4
56	2	Nut	DIN439-A4-M6
57	5	Screw	DIN912-A4-M6X16
58	5	Washer	DIN125-A4-Ø6,4
59	1	Spindle nut socket tool	991023
A1	1	Push button, with plastic cover	RA582000
A2	1	Push button gasket	735050
A3	1	Drilling template 40QT E1	996222
A4	1	Eye bolt	RD100896
A5	3	Screw M4 x 20 CSK Cross Head	RD100025
A6	1	Product Manual	996231
ITEMS SOLD SEPERATELY			
		Push button, with stainless steel cover	RA582010
		Push button, with stainless steel cover with hole	RA582020
		Circuit breaker 70Amp, (suits 40QT E1 24 Volt)	RA590070
		Circuit breaker 150Amp, (suits 40QT E1 12 Volt)	RA590150

* 991023 spindle nut socket tool [59] and RD100896 eye bolt [A4] are to assist with assembly during installation and should be retained for future use.

MOTOR EXPLODED VIEW

(parts list previous page)

40QT SINGLE SPEED 12V & 24V

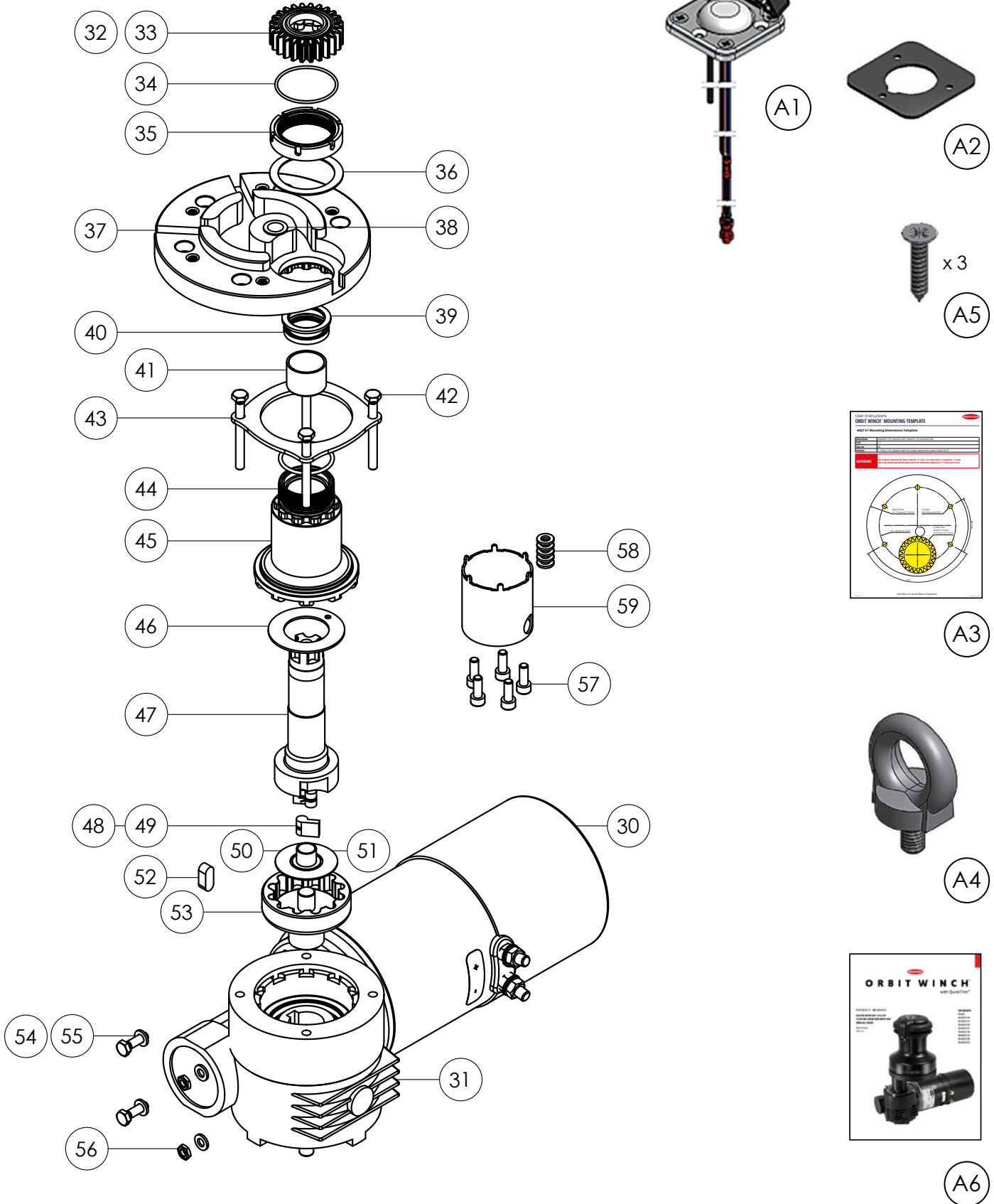

* When supplied as an E1 Electric Winch, drive gear [33], gear bearing [32] and compression ring [34] in the diagram above will be supplied separately in a plastic bag.

INSTALLATION

Step 1 : Determine winch mounting position

Determine the mounting position for the winch and ensure that the mounting surface is smooth and flat.

The winch should be positioned with the recommended line entry angle of 3-8° from horizontal. Refer to the diagrams below:

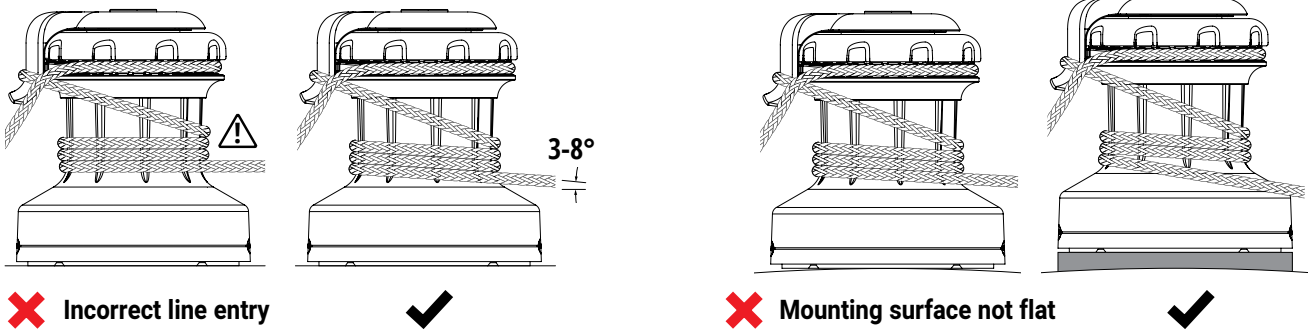

The drive gear should be aligned to the line entry as per the diagram and as indicated on the drilling template.

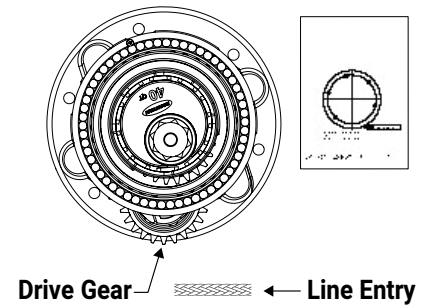

Step 2: Positioning the deck plate and motor unit.

1. Position the drilling template [A3] in the required position on the deck, ensuring that there is adequate flat space for the deck plate [37].
2. Considering the product dimensions, shown on page 24, check that there is adequate space below deck for the motor unit. You may choose to drill a small pilot hole to indicate the position of the centre of the motor's drive shaft [47], to assist with this.

See pages 24 for the minimum motor offset dimensions at the various positions.

Placing the deck plate on the motor unit in the various positions prior to installation can assist with visualising the motor position options.

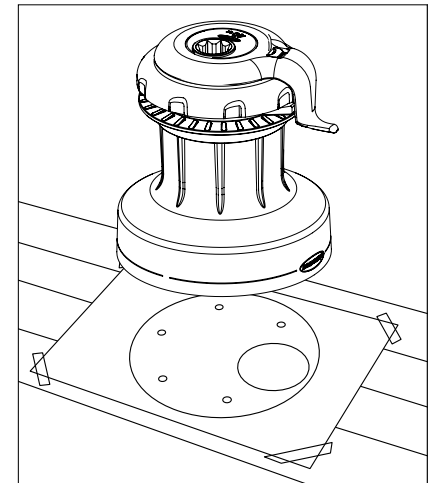

3. The 40QT Orbit Winch™ has the option of 10 different motor alignment positions (i.e. at 36° increments), as indicated on page 24. This facilitates fitting the motor unit into restricted under-deck cavities.

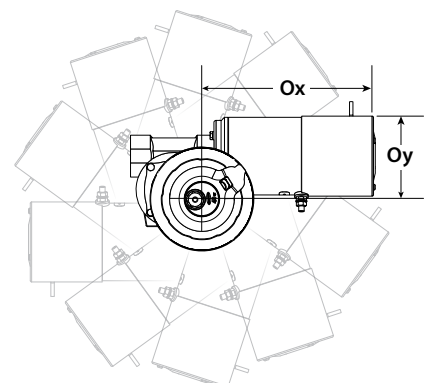

Step 3: Fitting the deck plate.

1. After confirming the mounting location and orientation of the winch, clean the mounting surface and tape deck plate drilling template [A3] on the mounting surface so that it matches the required winch and motor mounting position and orientation.
2. Drill $\varnothing 6.5\text{mm}$ holes for the M6 deck plate mounting bolts as per the drilling template [A3].
[Drill $\varnothing 9/32''$ holes if $1/4''$ bolts are being used].
3. Drill or cut a 54mm ($2\ 1/8''$) hole for motor drive shaft housing as per the drilling template.

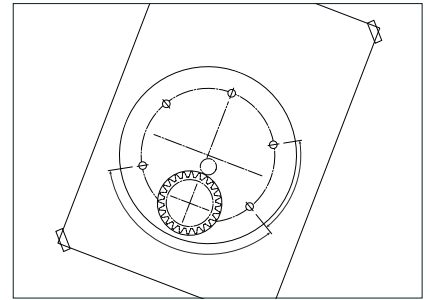

4. Apply sealant under the base of the deck plate [37] around the mounting holes.
For mounting on metal or carbon fibre surfaces, the deck plate must be completely isolated from the mounting surface to prevent galvanic corrosion.
 5. Fit the deck plate [37] to the deck using large washers and nuts below deck.
Apply Tef-Gel™ under the head of each mounting fastener to isolate it from the aluminium centre stem [17]. To avoid wearing the anodised surface of the deck plate [37], use a hex key to prevent the fastener from turning and use a spanner to tighten the nuts from below.
- 5 x M6 or $1/4''$ Grade 316 stainless steel fasteners. Use of grade A4-70 hexagon socket cylinder head screws is recommended, installed at a torque setting of no more than 7.1Nm as per industry standards.

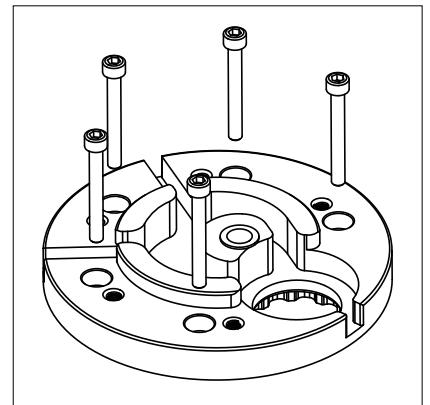

* Note: Deck fastenings are not supplied.

Fastener length = thickness of deck plate + deck thickness + sufficient additional length for washers (or backing plate) and nuts below deck.

Step 4: Fitting the motor to the deck plate.

* **Correct alignment of the motor unit during assembly is essential. Improper alignment can cause excessive noise and potentially dangerous vibration and lead to premature wear of bearings and gears. Proper installation will require two persons.**

1. Remove centre locknut [35] from drive shaft housing [45] of motor unit.
2. Fit the supplied eye bolt [A4] to the top of the motor drive shaft [47] and attach a strong rope to facilitate lifting the motor unit up into position through the hole in the deck, deck plate and clamping ring as shown below.
3. Using the rope, raise the motor unit so that the drive shaft protrudes through the large hole in the deck and deck plate [37]. A lifting device is recommended when raising the motor unit.
4. Rotate the motor unit into the required position to suit the under-deck cavity, ensuring that the motor is aligned properly – The protruding detail on the drive shaft housing [45] flange must fit snugly into the recesses on the deck plate to allow the motor top flange to fit flush with the underside of the deck plate [37] [refer to diagrams below].
5. Install the seal dust cover [39] and isolation washer [36] into the top of the deck plate [37].
6. Ensure that the compression ring [34] is in the groove on the top face of the centre locknut [35].
7. Fit and securely tighten the centre locknut [35] using the spindle nut socket tool [59] provided.

* Note: Do not use a sealant between the centre locknut [35] and deck plate [37]. An O-ring [44] ensures a waterproof connection.

Extra waterproofing can be achieved by applying sealant to the top of the deck plate [37] around the centre locknut [35] after installation.



Motor unit lifting eye bolt

✗ Incorrect mating of drive shaft housing top flange with underside of deck plate

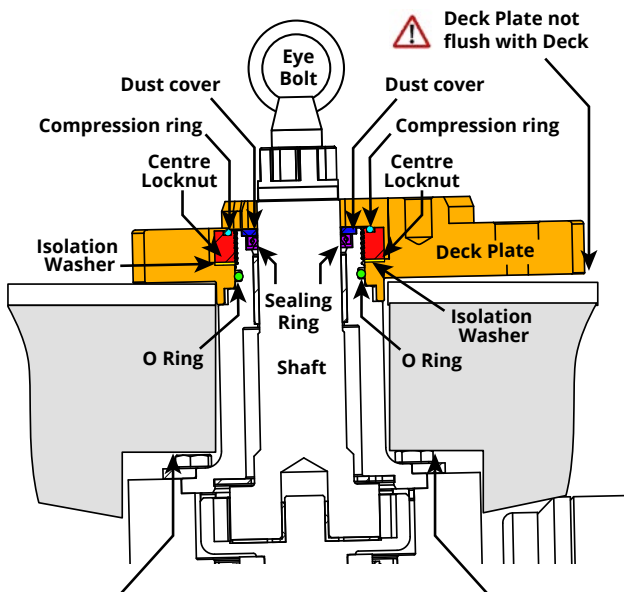

⚠ Non-aligned hole in deck preventing correct motor alignment

⚠ Inadequate underdeck clearance preventing correct motor alignment

✓ Correct mating of drive shaft housing top flange with underside of deck plate

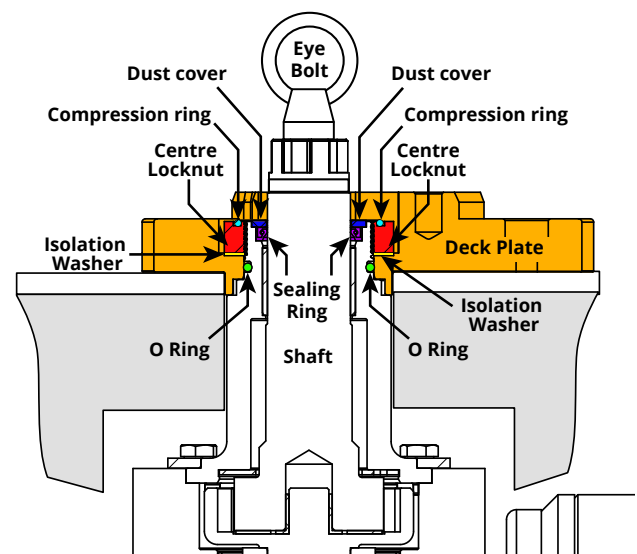



Step 5A: Fitting winch to the deck plate.

* Note: If fitting an E1 Electric Conversion unit to an existing manual winch go to step 5B.

1 Remove winch self-tailing arm.

Pull back the spring-loaded release latch on the self-tailing arm with a fingertip ①, then rotate the arm slightly in an anti-clockwise direction ② until it can be lifted clear of the winch ③. Remove the closing plate [2] and closing washer [3] and set all three parts aside for now.

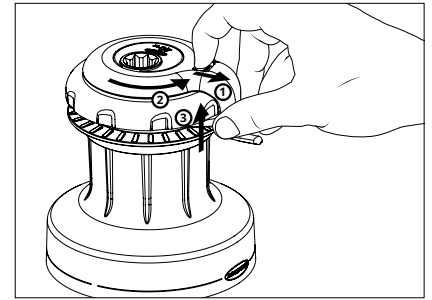

2 Remove the drum.

Grip the top of the drum assembly [7] with your fingers and pull vertically upward to remove it from the centre stem [17]. As the winch is not fixed to the deck yet, you may need to push gently with your thumbs against the central drive shaft [11] to separate the parts. Set the drum assembly [7] aside for now.

3 Insert the drive gear and fit to deck plate.

Insert the drive gear [33] into the recess in the centre stem [17]. While holding the centre stem and drive gear [33] in place, position the centre stem over the deck plate [37] and adjust back and forth until the drive gear engages into position on top of the motor drive shaft [47].

Adjust the winch base so that the 5 mounting holes align with the mounting holes on the deck plate [37].

Fit the winch base to the deck plate using the 5 screws (M6x16) [57] and washers [58] supplied. Apply Tef-Gel™ under each washer to isolate it from the aluminium centre stem. Use a medium strength thread lock on the screw threads. Install at a torque setting of no more than 7.1Nm as per industry standards.

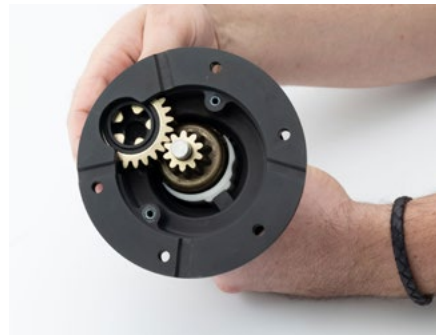
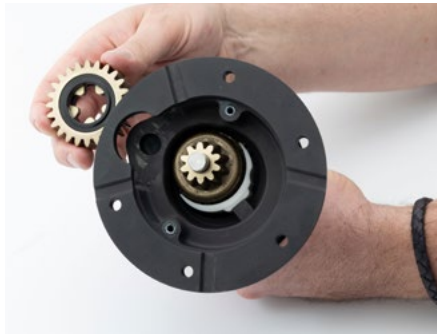

4 Re-assemble the winch drum.

Lift the drum assembly [7] over the centre stem [18], then slide it fully down into position. Lay the closing washer [3] in its recess within the self tailer, taking care that the correct side is facing upward. Place the closing plate [2] over the central drive shaft [11], so that it rests on the top of the centre stem [17]. A pip on the bottom of the closing plate [2] will locate in a dimple in the aluminium surface when it is in its correct orientation, leaving the bayonet notches around the edge exposed.

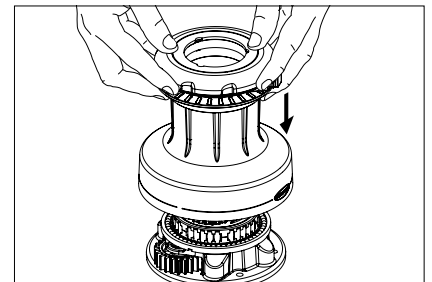

5 Fit the self-tailing arm.

Position the self-tailing arm [1] over the winch so that it overhangs the rope splitter [5]. Rest the arm in this position so that it is centred and sitting level on the closing plate.

Rotate the self-tailing arm to its desired position, checking again to ensure that it overhangs the rope splitter [5]. Allow the part of the arm opposite the spring-loaded release latch [1.3] to align with a bayonet notch in the centre stem and drop into engagement. Pull back the spring-loaded release latch [1.3] on the self-tailing arm with a fingertip ① and allow the arm to seat itself in the bayonet notches all the way around. Then rotate the arm slightly in a clockwise direction ③ and listen for the audible "click" indicating it is locked in position ②. A red flash should not be visible on the spring loaded release-latch [1.3] which indicates it is fully engaged.

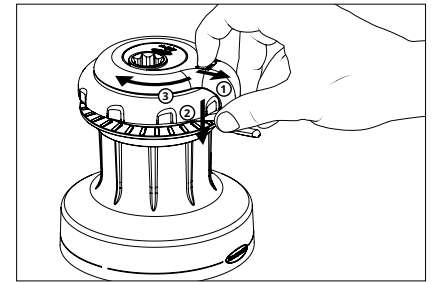
Step 5B: Fitting existing manual winch to electric conversion unit

1. Remove existing winch from the deck (refer to step 5A for instructions on how to gain access to the winch mounting bolts to remove winch from the deck).
2. Once the winch is removed from the deck ensure the deck and existing mounting holes are cleaned of any old or residual sealant. Note: existing hole pattern matches mounting holes of the deck plate [37].

3. Preparing winch for electric conversion.

Lift the roller bearing assembly [9] and ball bearing race assembly [10] off the centre stem. Remove the gear axle [15] and output gear [16] from the machined recess of the centre stem [17]. Use a small flat screwdriver under the head plate of the axle to pry it upward if necessary.

4. Remove the base plate.

Flip the centre stem [18] upside down and use a 4mm hex key to remove the 2 x M5 cap head screws [21] and remove the base plate [20].



5. Insert the drive gear [33] into the recess in the centre stem [17]. While holding the centre stem and drive gear [33] in place, position the centre stem over the deck plate [37] and adjust back and forth until the drive gear engages into position on top of the motor drive shaft [47]. Adjust the winch base so that the 5 mounting holes align with the mounting holes on the deck plate [37].

Fit the winch base to the deck plate using the 5 screws (M6x16) [57] and washers [58] supplied. Apply Tef-Gel™ under each washer to isolate it from the aluminium centre stem. Use a medium strength thread lock on the screw threads. Install at a torque setting of no more than 7.1Nm as per industry standards.

Replace the ball bearing race assembly [10] and the roller bearing race assembly [9].

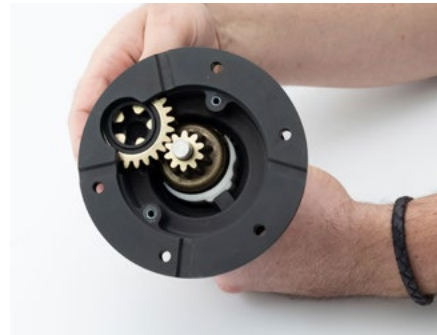
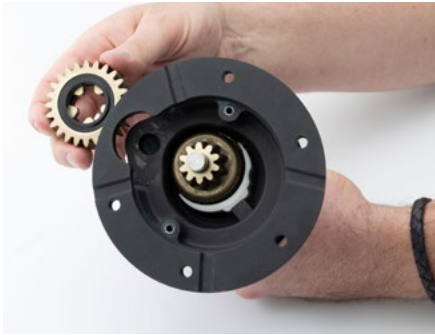

6 Re-assemble the winch drum.

Lift the drum assembly [7] over the centre stem [18], then slide it fully down into position. Lay the closing washer [3] in its recess within the self tailer, taking care that the correct side is facing upward. Place the closing plate [2] over the central drive shaft [11], so that it rests on the top of the centre stem [18]. A pip on the bottom of the closing plate [2] will locate in a dimple in the aluminium surface when it is in its correct orientation, leaving the bayonet notches around the edge exposed.

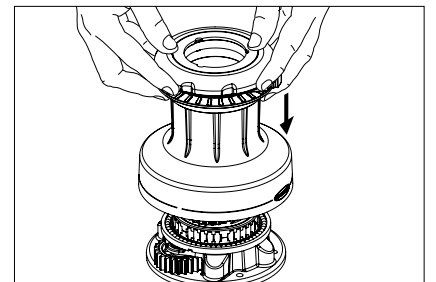

7 Fit the self-tailing arm.

Position the self-tailing arm [1] over the winch so that it overhangs the rope splitter [5]. Rest the arm in this position so that it is centred and sitting level on the closing plate.

Rotate the self-tailing arm to its desired position, checking again to ensure that it overhangs the rope splitter [5]. Allow the part of the arm opposite the spring-loaded release latch [1.3] to align with a bayonet notch in the centre stem and drop into engagement. Pull back the spring-loaded release latch [1.3] on the self-tailing arm with a fingertip ① and allow the arm to seat itself in the bayonet notches all the way around. Then rotate the arm slightly in a clockwise direction ③ and listen for the audible "click" indicating it is locked in position ②. A red flash should not be visible to on the spring loaded release-latch [1.3] which indicates it is fully engaged.

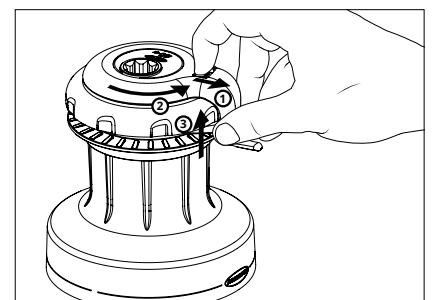

Step 6: Fitting the push button

- * Note: The push button [A1] requires 25mm depth clearance behind mounting surface.
 The push button is supplied with 500mm (19 5/8") of cable and the motor unit with 1400mm (55 3/16") of control cable. If the push button connection to the motor unit requires more than 1500mm (59") of cable you will need to provide your own extension cabling.
- 1 Select the desired position for the push button [A1].
 - 2 Drill a $\varnothing 19$ mm (3/4") hole at the centre of the push button location and a 5mm (3/16") hole immediately beside it for the breather tube. Or drill a $\varnothing 25$ mm (1") hole, at a 2mm offset to the centre of the push button location. Refer to the push button drilling diagram below.
 - 3 Using the supplied push button gasket [A2] as a template, drill 3 x $\varnothing 3$ mm (1/8") holes for the mounting screws.
 - 4 Ensure the clear breather tube is inserted into the bottom of the push button.
 - 5 Fit gasket [A2] and push button [A1] in place (with hinged cover opening upwards, if mounted on vertical surface).
 - 6 Apply a small amount of sealing compound to the mounting holes.
 - 7 Fasten push button with provided 3 pcs. M4 x 20 CSK screws [A5].

DRILLING TEMPLATE PUSH BUTTON

NOT TO SCALE

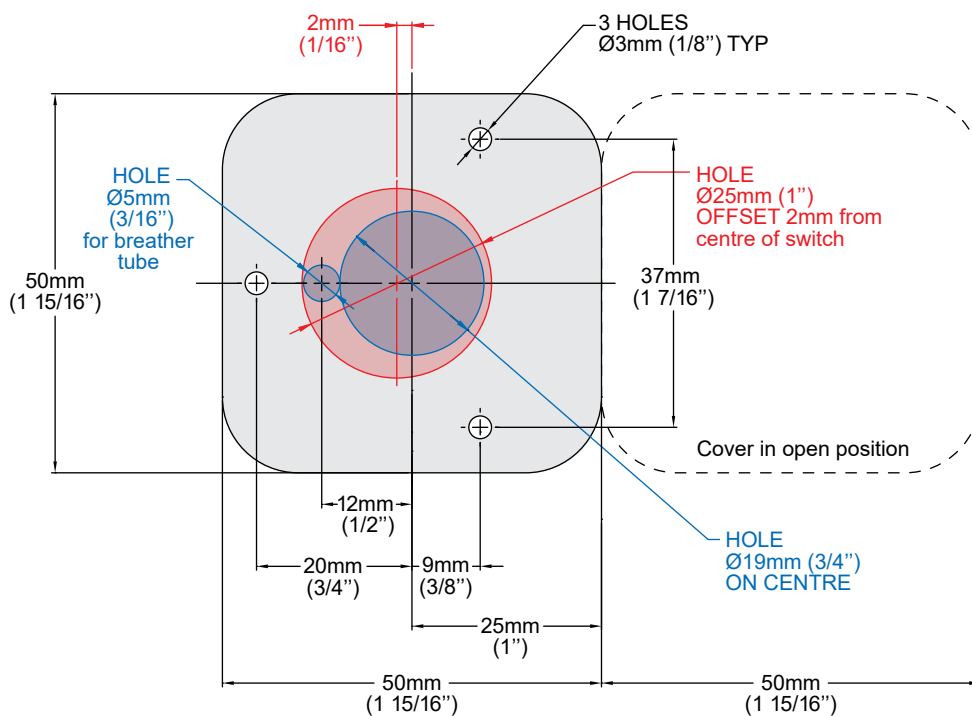

Step 7: Connecting the push button to the motor

- Connect wires from push button to wires from motor unit as per electrical connection diagram on page 17 Detail A.

Step 8: Connecting motor to the battery

- Measure the total wire run distance from the battery to the motor unit and back to the battery.
- Refer to table below to determine the required motor unit to battery wire size (cross-section area), circuit breaker/fuse size and total battery capacity (Ah).
- Connect the motor unit to the battery, with the appropriate circuit breaker or fuse in the positive power wire line. The circuit breaker or fuse should be positioned as close to the battery as possible.

- * Note: The fuse should be a "slow blow" or "long delay" type to allow for start-up current spike.

WARNING: Do not use smaller wire than recommended in the table. This can cause malfunction of the winch and in worst case - FIRE. The wires should always be as short as possible.

WINCH	WIRE LENGTH *	12V. DC				24V. DC			
		WIRE SIZE	CIRCUIT BREAKER	ADDITIONAL BATTERY CAPACITY PER WINCH	MIN. TOTAL BATTERY BANK CAPACITY	WIRE SIZE	CIRCUIT BREAKER	ADDITIONAL BATTERY CAPACITY PER WINCH	MIN. TOTAL BATTERY BANK CAPACITY
40 QT E1	0-3m / 0-10ft	35 mm ²	120 A	114 Ah	300 Ah	25 mm ²	70 A	60 Ah	150 Ah
	3-8m / 10-27ft	50mm ²	120 A	114 Ah	300 Ah	35 mm ²	70 A	60 Ah	150 Ah

* Wire length = Total cable length from battery to motor and back.

ELECTRICAL CONNECTION DIAGRAM

40QT SINGLE SPEED 12V & 24V

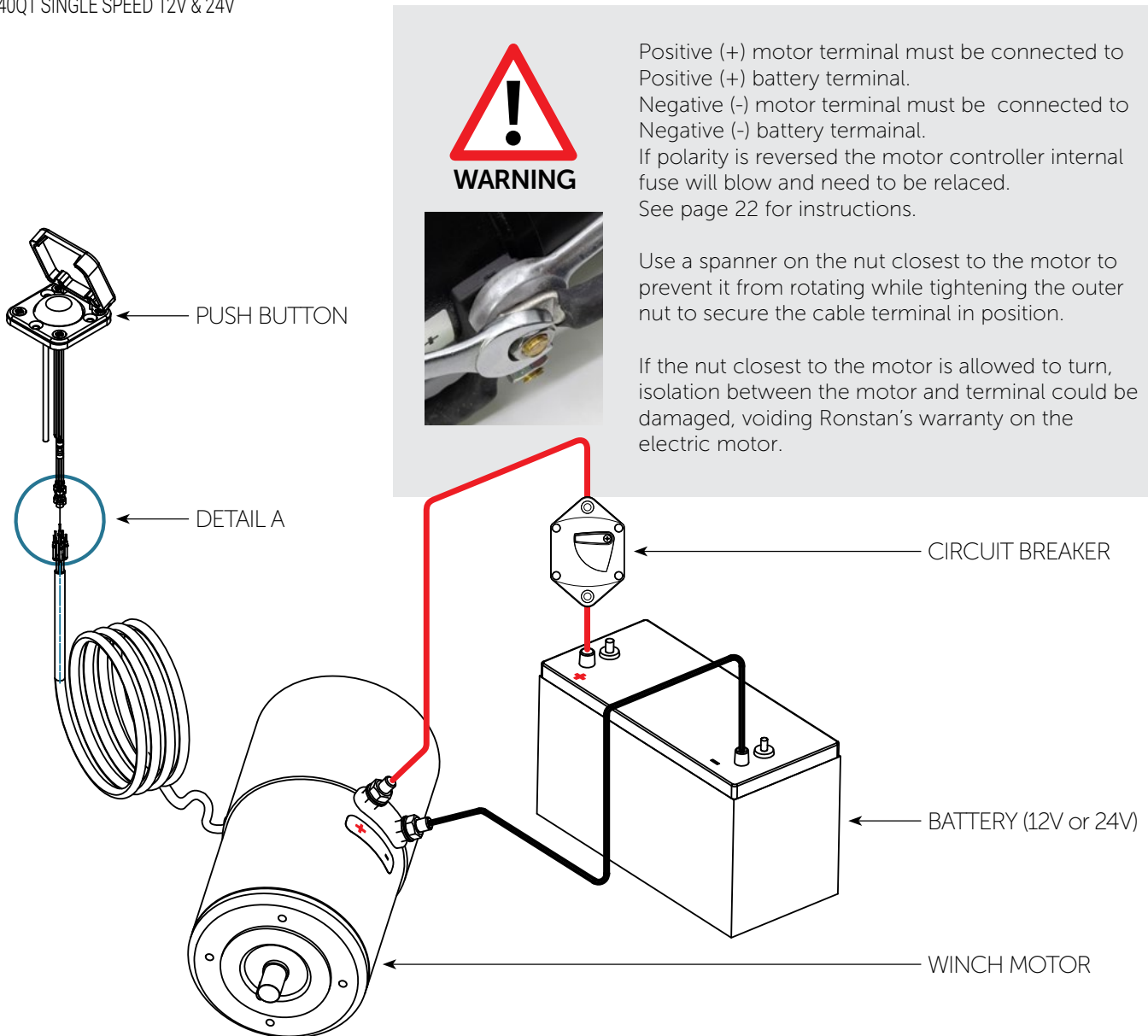

Positive (+) motor terminal must be connected to Positive (+) battery terminal.
 Negative (-) motor terminal must be connected to Negative (-) battery terminal.
 If polarity is reversed the motor controller internal fuse will blow and need to be replaced.
 See page 22 for instructions.

Use a spanner on the nut closest to the motor to prevent it from rotating while tightening the outer nut to secure the cable terminal in position.

If the nut closest to the motor is allowed to turn, isolation between the motor and terminal could be damaged, voiding Ronstan's warranty on the electric motor.

DETAIL A

STANDARD CONNECTION

PUSH BUTTON CABLE	MOTOR CABLE
1. Blue	= 1. Brown
3. Blue Black	= 3. Green
4. Red	= 4. Yellow

Wires are marked with numbered sleeves

Push button cable

- 1. Blue = Switch
- 3. Blue Black = Ground
- 4. Red = LED

Motor cable

- 1. Brown = Switch 1
- 2. White = Switch 2 (used for 2 speed motors only)
- 3. Green = Ground
- 4. Yellow = LED
- 5. Grey = Ratiometric current output
- 6. Pink = Low current cutout

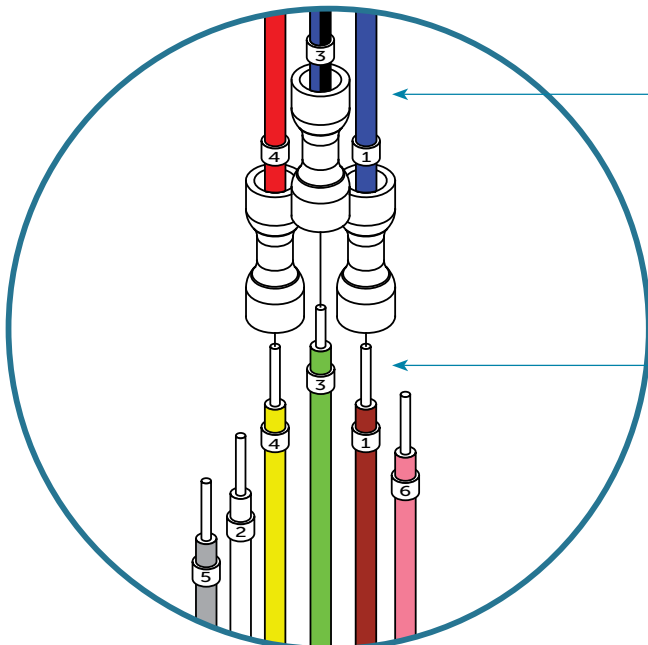

NOTE: Make sure that you familiarise yourself with the safety notices on page 4 of this manual before using the winch.

QUICKTRIM™

About the QuickTrim™ feature.

 QuickTrim™ is a patented innovation in self-tailing winches unique to Ronstan. It allows rapid easing of line tension without the need to remove the line from the self tailer.

Your winch has been delivered from our factory so that it will operate only as a traditional two-speed self-tailing winch unless you enable the QuickTrim™ functionality by following the instructions below. Once enabled, this feature should be demonstrated to new users so that they understand how to operate the winch correctly before use.

Optional enabling of QuickTrim™

Step 1:

Remove the self-tailing arm:

Pull back the spring-loaded release latch [1.3] with a fingertip (1), then rotate the self-tailing arm [1] slightly in a clockwise direction (2) until it can be lifted clear of the winch (3). Then remove the closing plate [2] and closing washer [3]. Set aside all three parts for now.

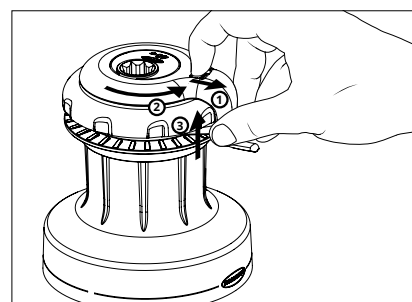

Step 2:

Locate and remove the countersunk cross-head screw as shown in the diagram. (Keep the screw for future use if you wish to disable the QuickTrim™ feature again).

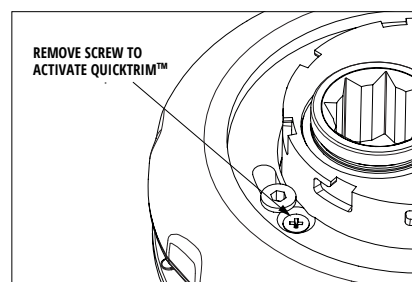

Step 3:

Re-assemble the closing washer, closing plate and self-tailing arm as described in Step 5A.5 of the installation instructions.

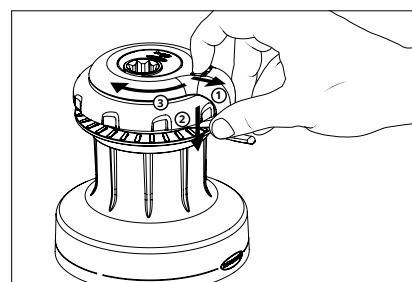

NOTE: Make sure that you familiarise yourself with the safety notices on p3 of this manual before using the winch.

USING QUICKTRIM™

The winch operates in the same way as a traditional two-speed self-tailing winch for tensioning, easing and casting off the rope. With QuickTrim™ the user can easily and safely make minor adjustments to sail trim without having to remove the winch handle, and without having to take the rope out of the self tailer.

- To release line tension, first hold the tail of the rope in one hand. Place your other hand on the top cover of the self tailer, with your fingers lying across the rope.
- Use the palm of the hand to grip and rotate the top cover anti-clockwise against the spring pressure and maintain it in that position. The self tailer is now able to turn beneath the cover, allowing the line to be eased off the drum in a controlled manner.

(As always, the grip of the winch depends on the load and the number of wraps on the drum; you can assist the movement of the rope on the drum while easing if desired, or try using fewer wraps on the drum).

- When the correct sail trim is achieved, simply allow the top cover to spring back to its original position. The self tailer is now locked, and the winch is ready for normal use.

QuickTrim™ is designed for minor adjustments and will be particularly useful in situations where frequent adjustment of tension is required in sheet, halyard and other applications.

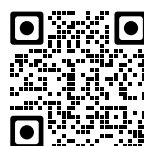
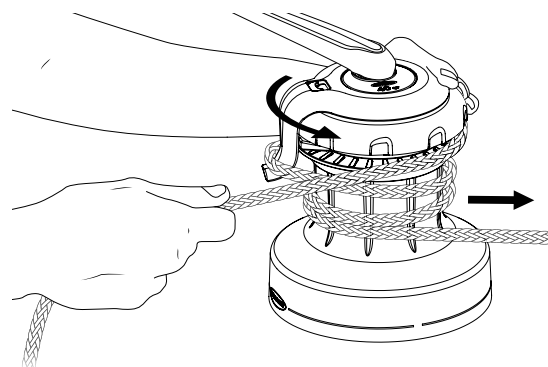

View the video showing the difference between 'traditional' and 'QuickTrim™' Operation.

SERVICE & MAINTENANCE

General Maintenance:

Note: Always shut off power to the winch before commencing any service or maintenance task!

As with all deck equipment, fresh water rinsing after each use is recommended to avoid accumulation of salt and other surface contaminants. We recommend a complete servicing of your winch (dismantle, clean and lubricate) every two years. Under extensive use such as racing, charter or extensive offshore sailing, complete servicing should be carried out on an annual basis.

We strongly recommend the use of ANDERSEN WINCH GREASE when lubricating your winch. ANDERSEN WINCH GREASE is a high-quality grease. Most other types of grease, including some labelled "marine grease", are not suitable and may lead to malfunction which could result in serious injury to the user and others.



Pawls should be inspected, and springs should be replaced every second year. It is important to use only genuine Ronstan or Andersen brand pawls and springs in your winch.

Winch Pawl & Spring Kit RA710052 contains 8 pawls and 16 springs.

Required for service:

- Winch handle
- ANDERSEN winch grease and small brush for application

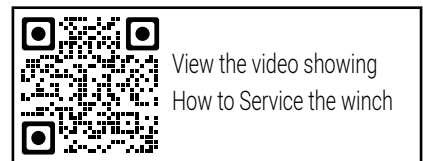

Winch Servicing Instructions:

Refer to the exploded view and parts list at the beginning of this manual for assembly details.

Proceed with the steps below to disassemble the winch, removing old grease and contaminants with white mineral spirits and inspecting all parts for wear or damage.

1. Remove self-tailing arm [1] and drum [7] as described in Installation Step 2&3. Check that the spring-loaded release latch [1.3] of the self-tailing arm is operating correctly and rinse thoroughly in fresh water.
2. Inspect the self tailer assembly [6]. If QuickTrim™ is enabled, check that the self tailer cover rotates against the spring pressure to allow the self tailer to turn in an anti-clockwise direction, and springs back as expected to lock the self tailer and prevent it from turning independently of the drum. Rinse the self tailer mechanism thoroughly in fresh water.
3. Insert a winch handle into the top of the drive shaft [11]. While holding the drive gear [13], use the handle to rotate the shaft slightly, while pulling up gently to find the release position; then pull up the drive shaft and remove it.
4. Remove pawls [11.3] and pawl springs [11.2] from the drive shaft.
5. Remove the spacer [12], drive gear [13] and ratchet gear [14] from the opening on the side of the centre stem [18].
6. Remove the shaft bearings [17] from inside the top of the centre stem.
7. To release the roller bearing [9], grip with fingertips from opposing sides and lift to snap it up over the containment lip on the centre stem [18].
8. Lift the ball bearing race [10] off the centre stem.
9. Remove axle [15] and output drive gear [16]. Use a small flat screwdriver under the head plate of the axle [15] to pry it upward if necessary. Note the correct position: the head plate of the axle must sit flush within the machined recess in the centre stem when reassembling the winch.
10. Check that the two "top hat" bearing inserts [19] in the winch base are in place, with holes clean and lightly greased.
11. Re-assemble the winch in reverse order. (Ensure that the shaft pawls are held closed when dropping the

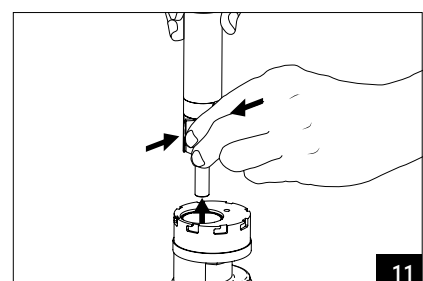
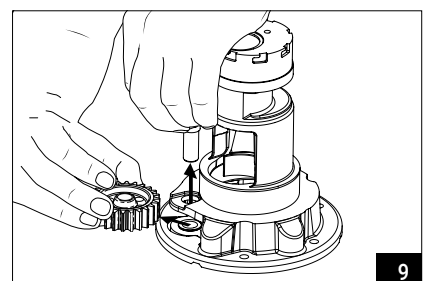
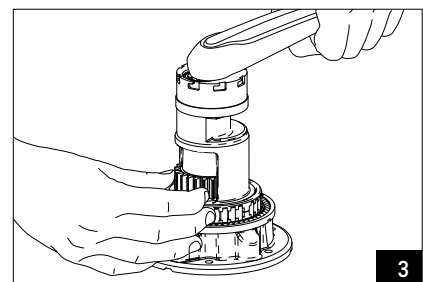
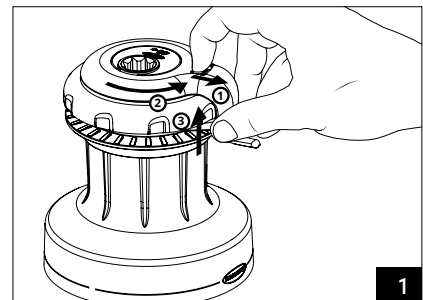

shaft down through the top of the stem to ensure the shaft bearings are not damaged).

- During assembly, use a small soft brush to lightly grease all gear teeth, drive shaft and axles. Both the roller bearing cassette [9] and ball bearing race [10] are self-lubricating and must not be greased.
- Apply only a very thin film of Andersen Winch Grease to the pawls. Do not use any other kind of grease for this purpose. Take care to assemble with springs in the correct orientation as shown in the diagram.

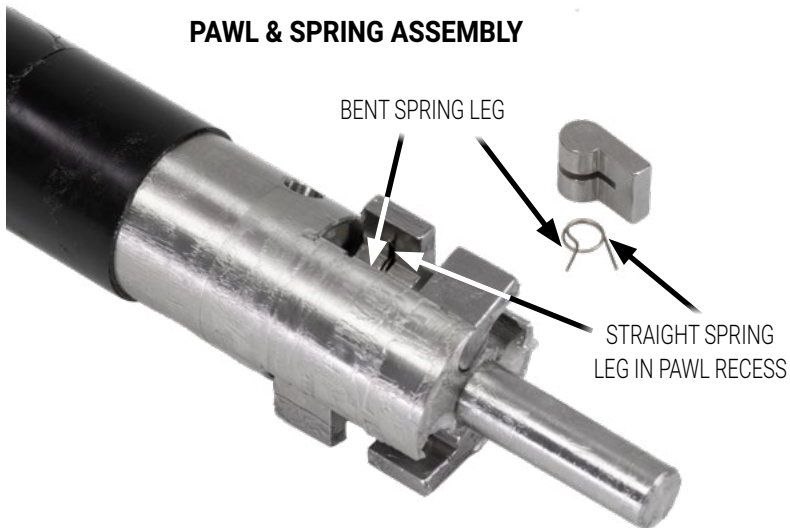

! Malfunctioning pawls may lead to unexpected release of the winch force resulting in serious injury to the user and others. Check the functioning of each pawl by depressing against the spring. The pawls should move smoothly, and automatically return to their normal position to engage within the gears. If the pawls do not work correctly replace the springs and check again.

ELECTRIC MOTOR UNIT SERVICE & MAINTENANCE

Note: Always shut off power to the winch before commencing any service or maintenance task!

- The winch on top of the electric motor unit should be serviced as per the General Maintenance instructions on the previous page.
- The electric motor is a sealed unit and does not require regular servicing of internal parts.
- To avoid potential sea water ingress and to maximise the service life of your electric winch motor unit, it is recommended to re-lubricate the motor unit drive shaft sealing ring [40] once a year. Under intensive use, such as racing, charter, or blue water sailing, we recommend lubrication twice a year.

To access the sealing ring [40], it is necessary to remove the winch from the deck plate [37]. Refer to the Winch Product manual for instructions.

The sealing ring should be lubricated with a grease such as Klüber ISOFLEX TOPAS NB 52, or Andersen Winch Grease.

Drive shaft Sealing Ring



TROUBLESHOOTING

E1 IN-BUILT SYSTEM PROTECTION

The E1 Electric Motor Unit has a very high level of in-built system protection, via monitoring of various operating parameters, its integrated controller and other protection/control componentry.

This functionality includes:

- Reverse polarity protection
- Mechanical overload protection
- System low voltage detection
- Thermal overload protection
- Continuous run time limiting
- Accidental start protection

REVERSE POLARITY PROTECTION

If the motor unit is inadvertently connected to the power system with reversed polarity the motor's internal fuse will blow. The fuse will have to be replaced before the motor will start again.

To replace the fuse:

- Remove the cable ties that secure the control cable to the outside of motor cover.
- Remove the two screws from the end of the outer motor cover (using a #1 Phillips head screw driver) - refer to picture below.
- Rotate the outer motor outer cover slightly and carefully pull the motor cover away from the motor unit.
- Note: After the first 5mm (3/16") the O-ring will release the cover, there will be no resistance the rest of the way, and very little force should be used so as not to damage the internal wiring connections.
- When the outer cover is clear of the internal components, set it to one side so that there is no tension on the internal control cable wires.
- Replace the 5A glass fuse, located on the PCB as shown below.
- Reassemble in reverse order. Make sure that the internal cables are not wedged between the cover and internal components and again that no force should be required to replace the cover until the O-ring is reached. Before pushing the cover on the final few millimetres over the O-ring, make sure that the screw holes in the outer cover are aligned with the threaded rods inside. Refer to picture below for threaded rod position.



Motor outer cover attachment screws



5A Glass Fuse PCB location



Threaded rods for motor outer cover attachment screws

STATUS CODES

The E1 "Intelligent" Illuminated Push Button acts with the controller to flash status codes to assist in trouble shooting in the event of overload or where other system protection intervention occurs. The push button will flash a number of times in quick succession, followed by a short break, and then repeat again.

The number of flashes indicates the system status as follows:

- **1 Flash Maximum working load has been reached.**

The motor has cut out after reaching the pre-set maximum load for electrical operation of the winch. Status will automatically reset to normal and the winch will be ready for use when the load has decreased below the max limit, and the button is pressed again.

- **2 Flashes Low system voltage detected.**

This will occur if the system voltage goes below 10.5 Volts (for 12V systems) and 21 Volts (for 24V systems) in idle state, or below 7.0 Volts (for 12V systems) and 18 Volts (for 24V systems) while running. Batteries should be recharged before the winch is used again. Status will automatically reset to normal and the winch will be ready for use when the voltage comes back above 11.0 Volts (for 12V systems) and 22 Volts (for 24V systems).

- **3 Flashes Max temperature of the motor has been reached.**

The motor has overheated. Status will automatically reset to normal, and the winch will be ready for use when the motor has cooled down sufficiently (this may take some time). Ensuring adequate ventilation around the motor will help to avoid overheating.

- **4 Flashes Max temperature of the control board has been reached.**

The temperature of the control board has exceeded 85°C. Status will automatically reset to normal when the control board temperature drops below 75°C. Ensuring adequate ventilation around the motor will help to avoid overheating.

- **5 Flashes Push button error.**

Operation of the winch is prevented because a push button has been pressed when system power up is initiated – i.e. when power is supplied to the winch by closing the CB or battery switch. To reset status to normal, turn off the power at the circuit breaker or battery switch, ensure no push buttons are pressed and turn on power again.

- **6 Flashes Maximum continuous motor run time has been reached.**

The motor has been running continuously for approximately 10 minutes. To reset status to normal, release the push button, then press it again to resume operation.

- **7 Flashes Max relay cycles reached.**

The motor relay has been activated 20,000 times and will need to be replaced to ensure continued safe operation. Contact Ronstan or your local Andersen Winches distributor for advice.

INSTALLATION DIMENSIONS

SIZE 40QT ORBIT WINCH

NOT TO SCALE

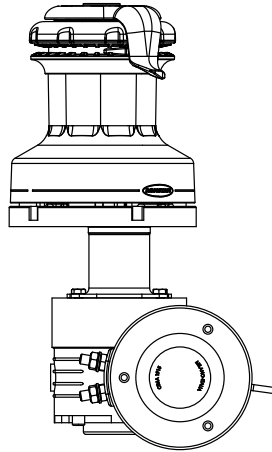
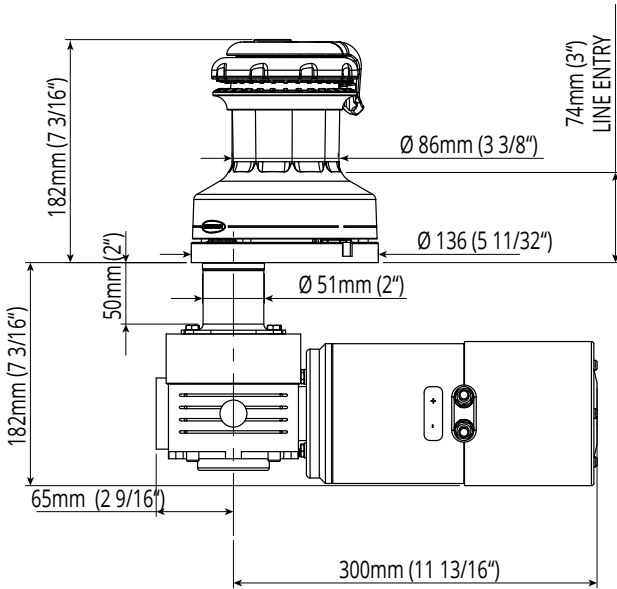
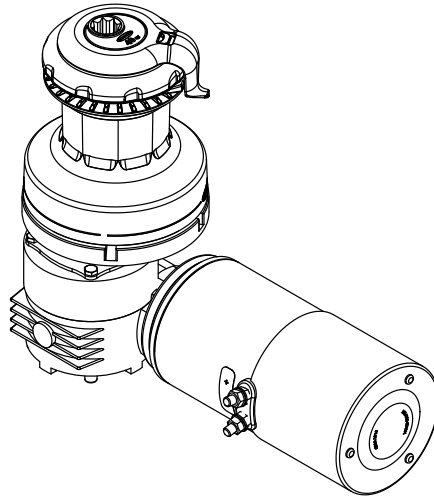
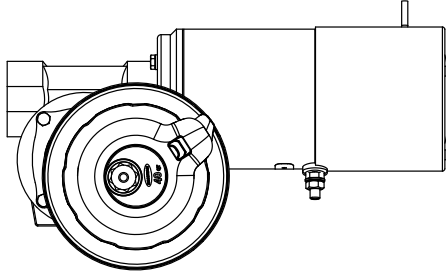

WEIGHTS	kg	lb
Winch only	3.1	6.8
Winch & motor unit	25.7	56.5

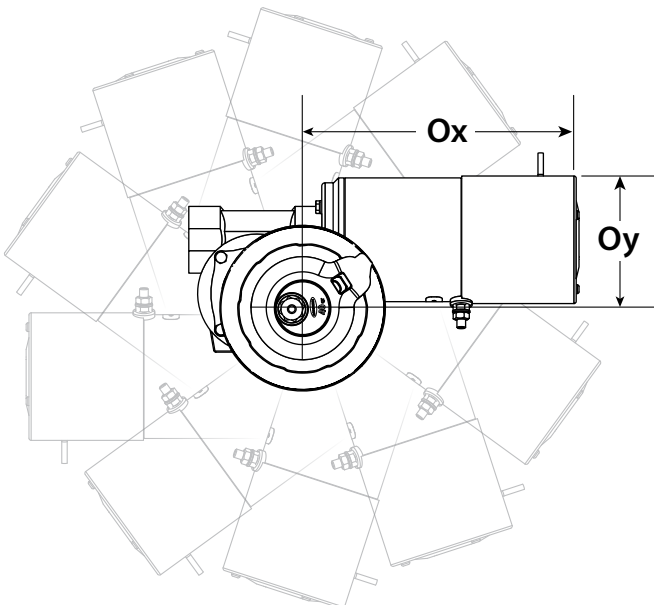

MOTOR OFFSET	mm	in
Minimum Ox	255mm	10 1/16
Minimum Oy	95mm	3 3/4
Maximum Ox	339mm	13 11/32
Maximum Oy	122mm	4 13/16

^ Values with motor in optimum position to minimise Ox or Oy. Oy value includes allowance for push button cable and fitting on the motor housing. Motor can be rotated at 360 intervals which will change Ox and Oy values.

User Instructions

ORBIT WINCH™ MOUNTING TEMPLATE



40QT E1 Mounting Dimensions Template

Winch Model	RA640201100, RA640201200, RA640251100, RA640251200
Scale	1:1
Page size	A4
Fasteners	5 x M6 or 1/4" stainless steel hex socket countersunk screws, Grade A4-70

IMPORTANT This template document has been created at 1:1 scale. It is critical that it is printed at 1:1 scale. Check any printed/reproduced copies match the dimensions indicated at 1:1 scale prior to use.

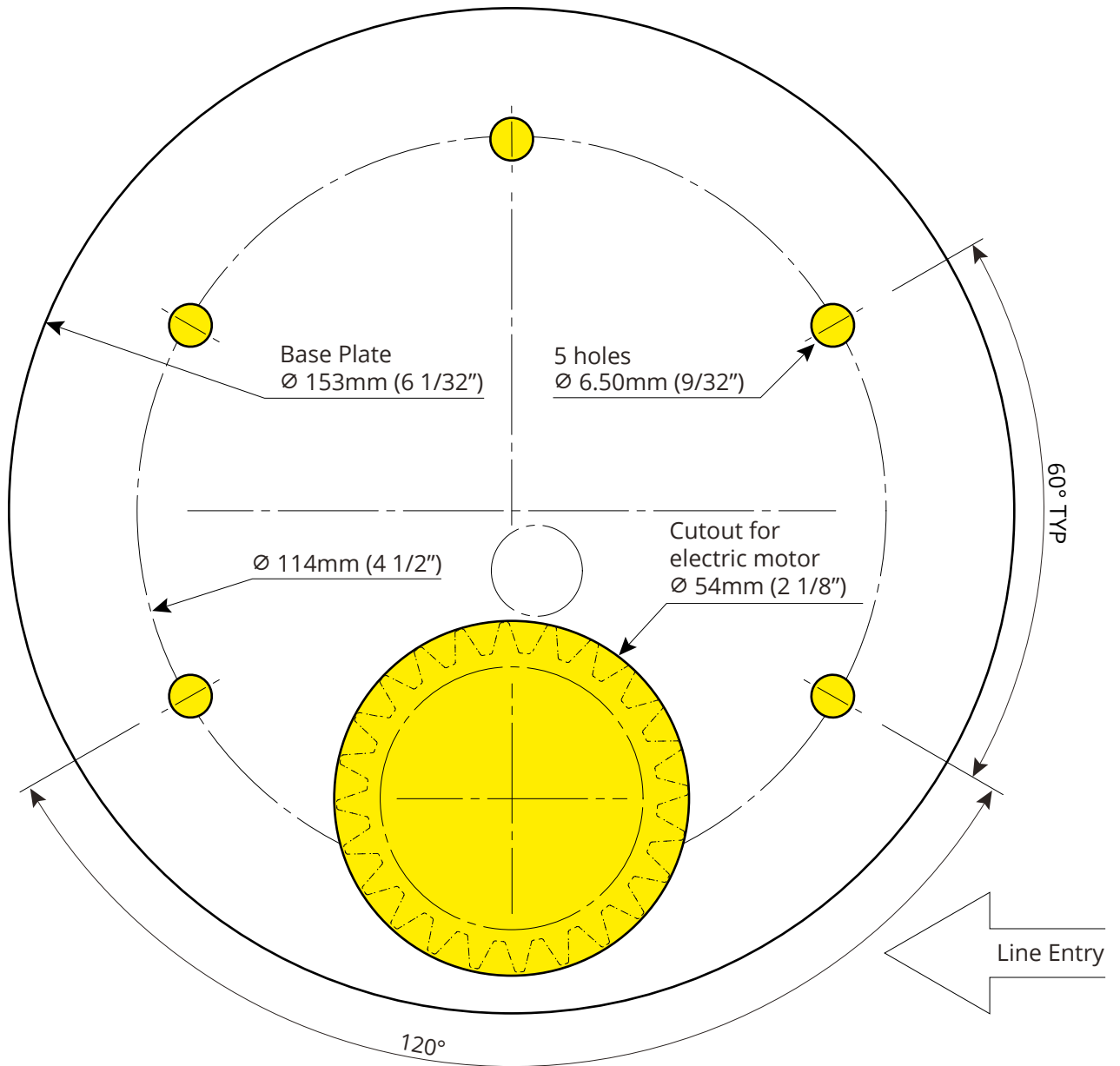

Self-tailer arm can be fitted in 8 positions.

**WORLDWIDE DISTRIBUTION & SUPPORT**

www.ronstan.com

WARRANTY

www.ronstan.com/warranty

office@ronstan.dk

www.ronstan.com